

INSTALLATION GUIDE



SUPERTIE™

FIBERGLASS FORM-TIE SYSTEMS

ROCKGRIP™

6K & 15K ANCHOR SYSTEMS

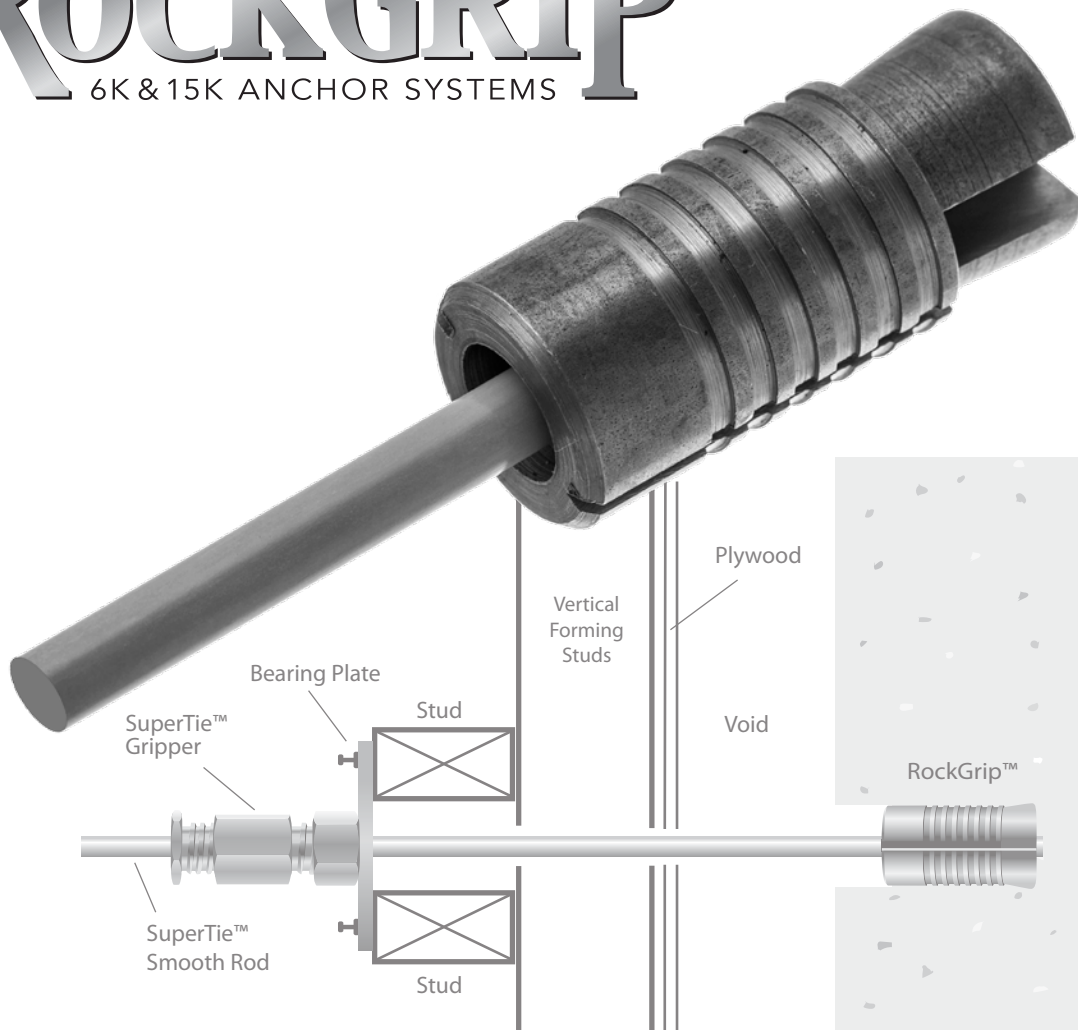

ROCKGRIP™

6K & 15K ANCHOR SYSTEMS



RockGrip™ is our anchoring device for the smooth SuperTie™ rod in single-forming applications. It is mechanical in nature and must be set by the "Rockgrip Setting Tool," which can be driven by hand or under power with any roto-hammer. RockGrip is easy to use, eliminates epoxy cure time, is less expensive than alternatives, requires less anchor depth, and eliminates plugging and patching. Anchors are available for both 6K (6,000 pounds ultimate tensile strength) and 15K (15,000 pounds ultimate tensile strength) systems.

SuperTie™ RG6000 RockGrip™ 6K – 6,000 lbs. pullout strength. (3,000 lbs. S.W.L.)*

Use an electrically operated roto-hammer, with a 1" diameter drill bit. Drill to a depth of at least 2-3/4 inches. Note: The drill bit must conform with ANSI B94.12. Clean out the debris from the hole with compressed air or a hand held aspirator.

SuperTie™ RG15000 RockGrip™ 15K – 15,000 lbs. pullout strength. (7,500 lbs. S.W.L.)*

Use an electrically operated roto-hammer, with a 1-1/4" diameter drill bit. Drill to a depth of at least 3-3/4 inches. Note: The drill bit must conform with ANSI B94.12. Clean out the debris from the hole with compressed air or a hand held aspirator.



* Safe Working Load (S.W.L.) allows a 2:1 Safety Factor

STEP 1:

Select and drill the hole locations where RockGrip™ is to be installed. A minimum of 18 square inches of sound material must surround each RockGrip™ anchor point. If less is available, on-site testing should be done to determine suitability. To help you determine the tie spacing pattern, please refer to our "Tie Load Determination Chart" on our website.

STEP 2: (See Figure 1)

Determine the length of rod required by adding the following measurements:

- (a) Depth of the hole for RockGrip™ assembly
- (b) Width of structure
- (c) Width of form
- (d) Gripper Length for 6K & 15K systems is 5"

STEP 3: (See Figure 2)

Assemble RockGrip™ onto the SuperTie™ Rod. The RockGrip™ unit will be positioned so that the back end of the jaw cluster will enter the hole before the shell.

STEP 4: (See Figure 3)

Slide the assembly into the hole that was drilled in step 1. Tap on the free end of the Rod to ensure that it has reached the bottom of the hole.

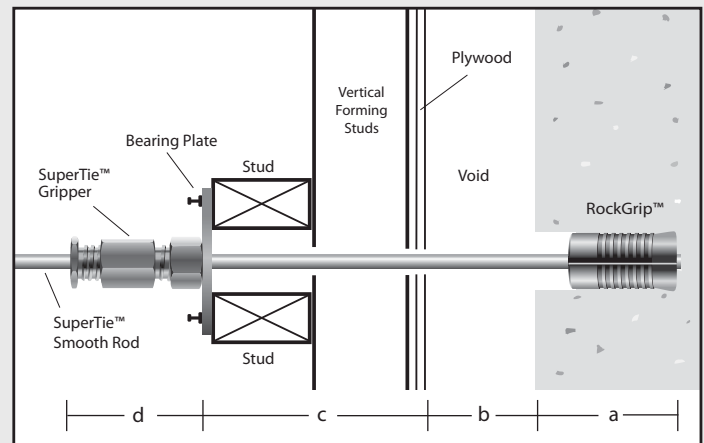

Figure 1.

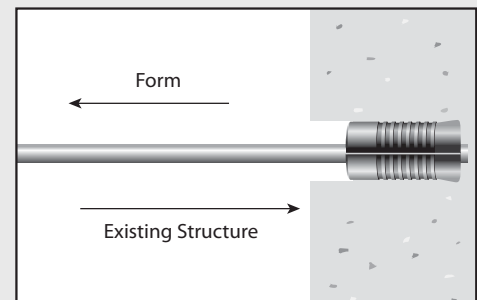

Figure 2.

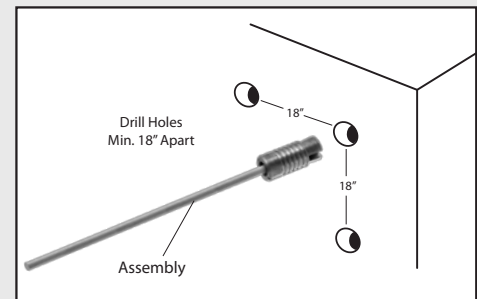

Figure 3.



RJD Industries, LLC

130 Los Aguajes Ave., Santa Barbara, CA 93101

(805) 456-5980 • rjdindustries.com • info@rjdindustries.com

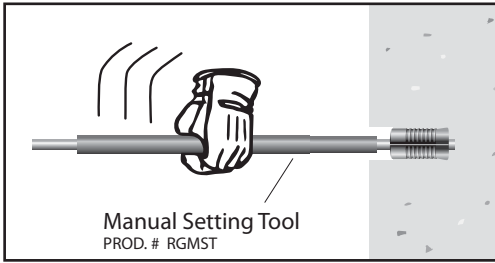

Figure 4.

STEP 5a: Manual (See Figure 4)

When using a “manual” Setting Tool, slide it over the Rod with substantial force, striking the RockGrip™ unit. Do this several times. The RockGrip™ is set when the shell is split (see step 6).

NOTE: Do Not Hit The Manual Setting Tool with a hammer or other striking tool.

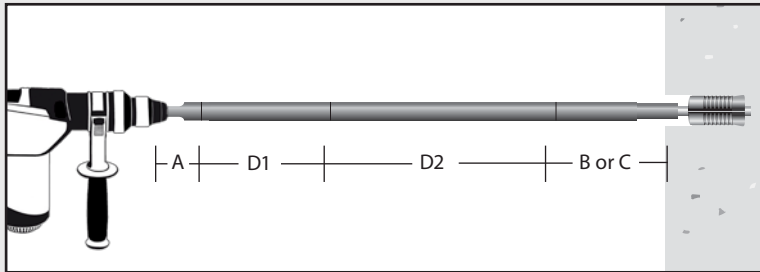

Figure 5.

STEP 5b: Powered (See Figure 5)

If use of a Roto-Hammer is preferred, the RockGrip™ Power Setting Tool (RGPST) components can still be used. Assemble a sufficient number of components of the RockGrip™ Power Setting Tool to fit over the entire length of Rod being used in this order:

- Part (A) fits into an SDS Max Roto-Hammer
- Part (B) fits RockGrip™ 6K System
- Part (C) fits RockGrip™ 15K System
- Parts (D1 & D2) as many 18” and/or 24” extensions as needed.

Using the “hammer” selection on your rotary hammer, hold the Setting Tool Assembly firmly against the RockGrip™ shell and apply power for approximately 30 seconds. The RockGrip™ is set when the shell is split. (see step 6)

Part Number	Description	Rod Covered
RGPST-A	Driven End	0 mm
RGPST-B	6K Driver	305 mm
RGPST-C	15K Driver	305 mm
RGPST-D1	457mm Extension	457 mm
RGPST-D2	610 mm Extension	610 mm

STEP 6 – (See Figure 6)

Pull the Setting Tool away from the RockGrip™ a few inches to allow visual inspection of the RockGrip™ shell. It should be split, indicating that the unit is adequately set. If no split is visible, repeat step 5.

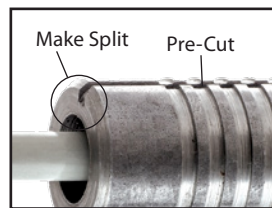

Figure 6.

STEP 7 – (See Figure 7)

An additional piece of Rod may be used to provide a method of aligning the form. Using a 5/16” drill bit (1/2” for 15K system), make holes about 2” deep, into which the “spreader” can be inserted (see Fig. 7). Cut these “spreader Rods” to an appropriate length so that the form will be aligned when touching them. Unit set when split is visible.

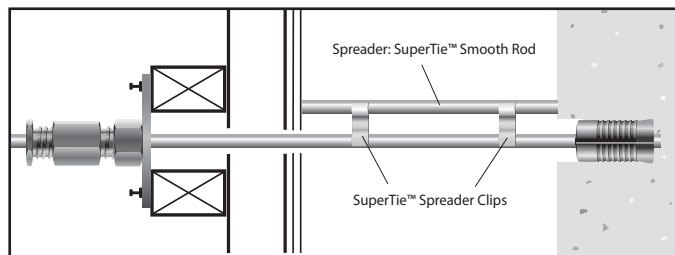

Figure 7.

STEP 8 – (See Figure 7)

Slide form panels onto the anchored ties, up against the “spreader Rods”, then assemble Grippers and Wedges as described in “SuperTie Installation Guide.”



- Eliminates epoxy cure time.
- Easy to use.
- Less expensive.
- Requires less anchor depth.

It is important to note, using a roto-hammer is advised when there is rebar in the substrate.





TECH DATA – COMPRESSIVE STRENGTHS

RJD's 6K SuperTie™ System:

Testing was done in material with compressive strengths of 2,200 lbs. or more. If jobsite material is of lesser compressive strength, "on-site testing" will be required to determine the depth of the hole needed to develop sufficient hold: if more than 7" a special RGPST-B will be needed. Drill bit hole 1".

RJD's 15K SuperTie™ System

Testing was done in material with compressive strengths of 15,000 lbs. or more. If the compressive strength of the embed material is at least 7,500 pounds, a hole depth of at least 3-3/4" is sufficient. If it's 7,500 pounds, drill at least 4-1/2" deep. If embed material is less than 2,200 psi, "on-site testing" must be done to find the depth required. Note: If more than a 7" deep hole, a special RGPST-C will be need to be added. Drill bit hole 1-1/4".

ROCK GRIP COMPONENT LIST

PRODUCT #	DESCRIPTION	PACKAGING	SHIP WT
RG6000	RockGrip™ 6K	50 per box	10.4 kg
RGMST6	RockGrip™ 6K Setting Tool (manual)	1 per box	2.7 kg
RG15000	RockGrip™ 15K	50 per box	17.2 kg
RGMST15	RockGrip™ 15K Setting Tool (manual)	1 per box	3.6 kg
RGPST	RockGrip™ Setting Tool (with Roto-Hammer)	n/a	n/a
RGPST-Part-A	Part A: Driven End	1 each	0.4 kg
RGPST-Part-B	Part B: 6K Driver	1 each	1.4 kg
RGPST-Part-C	Part B: 15K Driver	1 each	0.9 kg
RGPST-Part-D1	Part D1: 45.7 cm Extension	1 each	1.4 kg
RGPST-Part-D2	Part D2: 60.9 cm Extension	1 each	2.3 kg

technical questions: Info@rjdindustries.com

IMPORTANT: When using add mixtures, retardants, self-impacting concrete, or other products that create a full liquid head of pressure, a new safe working load must be used at a 2.5:1 ratio in lieu of the 2:1 safe working load which ultimately decreases your tie spacing.

scan for a distributor



RJD Industries, LLC
 130 Los Aguajes Ave., Santa Barbara, CA 93101
 (805) 456-5980 • rjdindustries.com

SuperTie™ Systems are sold exclusively through quality construction materials dealers. Scan the QR code to see our distributor locations or just call us for the name of the dealer nearest you.